

TEHROTECH



Your expert in partial finishing

Know-how, experience and innovative skills characterise our work in electroplating.



Professional surface finishing

With almost 40 years of experience and trained employees, our company specialises in bulk and rack goods and finishes turned, milled, punched and lasered parts in gold, silver, white bronze, nickel, tin and copper.

We look forward to working with you on your specific project.

TEHROTECH

Tehrotech GmbH
Industriestraße 54
75181 Pforzheim

Phone: +49 (0) 7231-9782-0
Fax: +49 (0) 7231-9782-31

info@tehrotech.de
tehrotech.com

Highest precision through innovative expertise

Due to the uniform finishing of the part to be coated, we achieve a high level of efficiency of the coating material used.

Thanks to this expertise and know-how, only the required functional area is coated with the coating thickness needed.

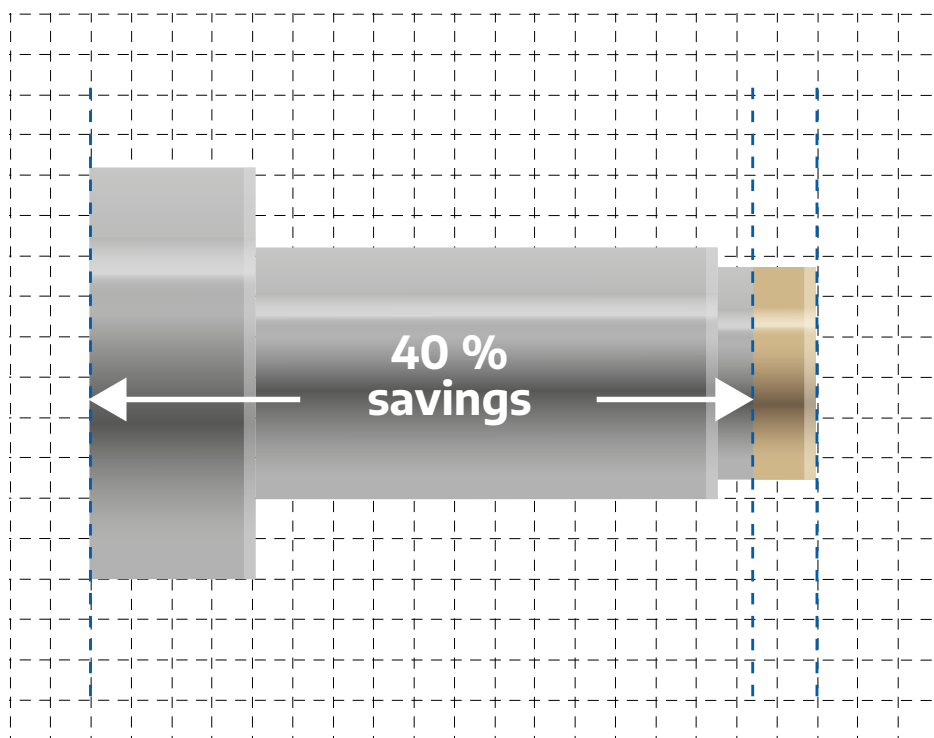
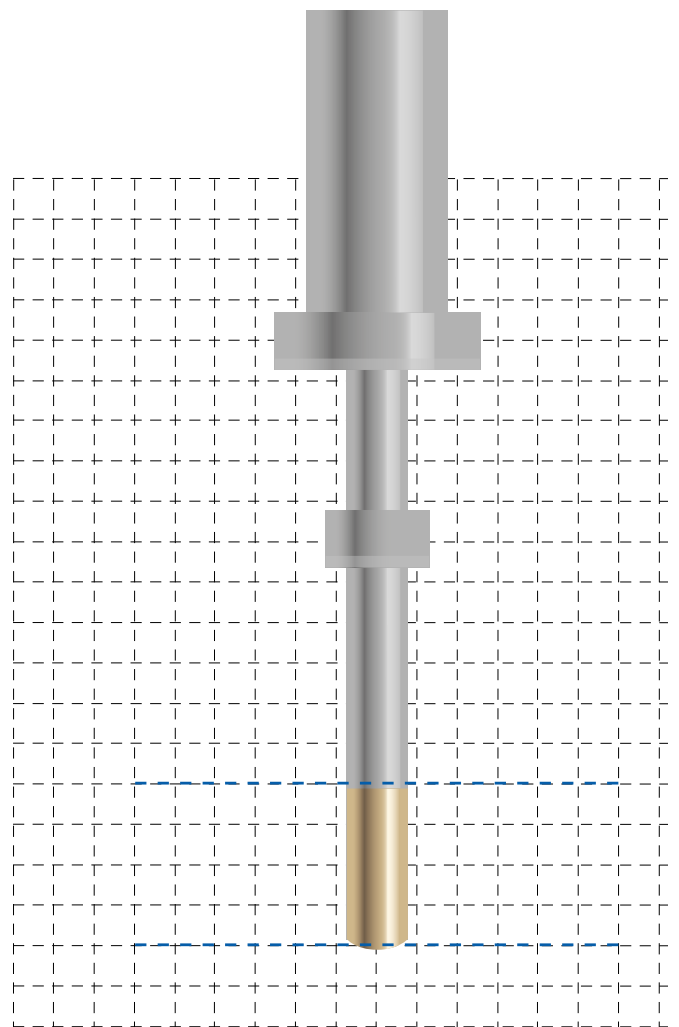

Benefit from the advantages

- + High savings potential
- + Greater cost-effectiveness
- + Resource efficiency